

BN 2708

Self-cutting threaded inserts

Stainless steel A1

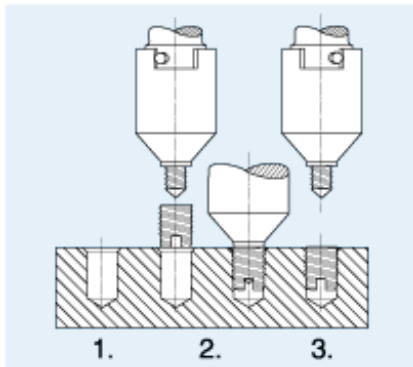

1. Drill the hole
2. Drive the insert into the workpiece (insert is cutting its own thread)
3. Disengage assembly tool

Article#	d ₁	P	d ₂	L
1472259	M3	0,5	5	6
1472267	M4	0,75	6,5	8
1472275	M5	1	8	10
1472283	M6a	1	9	12
1472291	M6	1,5	10	14
1472305	M8	1,5	12	15
1472313	M10	1,5	14	18
1472321	M12	1,5	16	22