

| | | | | | |
|---|--------------------|--------------------------|--|--|--|
|  | DIN 32501-5 | ~ISO 13918 IT | | | |
|---|--------------------|--------------------------|--|--|--|

Standard withdrawn

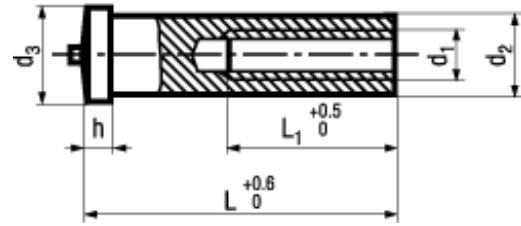

| |
|----------------------|
| BN 1430 |
| Weld studs |
| with internal thread |
| Steel |
| copper plated |

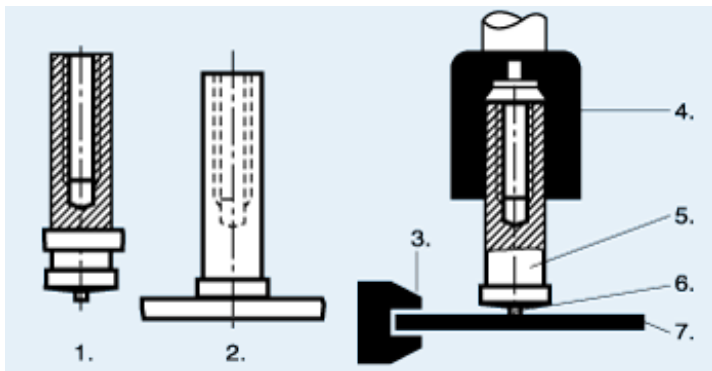
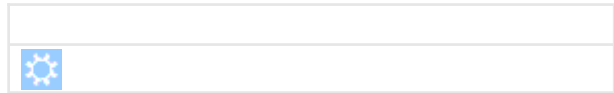

- 1. Before welding
- 2. After welding
- 3. Ground
- 4. Welding tong
- 5. Weld stud
- 6. Ignition head
- 7. Workpiece

| Article# | d ₁ | d ₂ | d ₃ | L ₁ | h | L |
|----------|----------------|----------------|----------------|----------------|---------|------|
| 1207865 | M3 | 5 | 6,5 | 5 | 0,8-1,4 | 8 |
| 1207873 | | | | | | 10 |
| 1207881 | | | | | | 12 |
| 1207903 | | | | | | (15) |
| 1674927 | | | | | | 16 |
| 1207911 | | | | | | 20 |
| 1207954 | M4 | 6 | 7,5 | 6 | 0,8-1,4 | 10 |
| 1207962 | | | | | | 12 |
| 1207970 | | | | | | (15) |
| 1674935 | | | | | | 16 |
| 1207989 | | | | | | 20 |
| 1207997 | | | | | | 25 |