

	DIN 32501-1	~ISO 13918 PT		37-3
---	-------------	------------------	--	------

Standard withdrawn

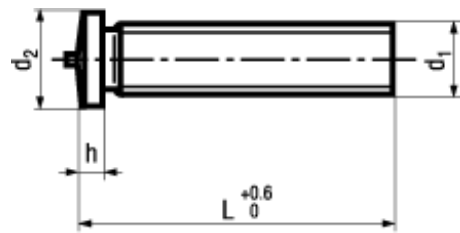

BN 1456
Weld studs
with external thread
Steel 37-3
copper plated

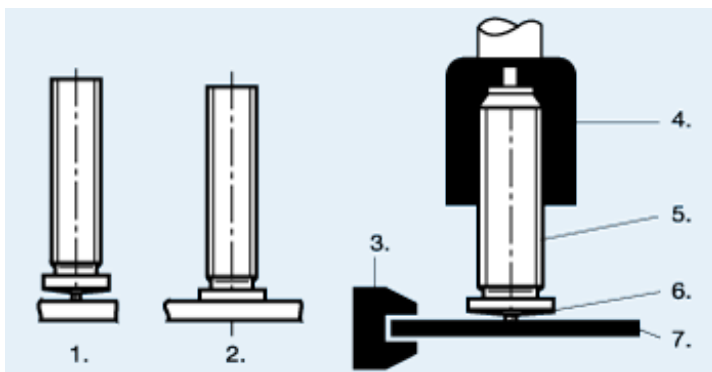
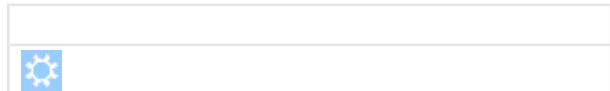

- 1. Before welding
- 2. After welding
- 3. Ground
- 4. Welding tong
- 5. Weld stud
- 6. Ignition head
- 7. Workpiece

Article#	d ₁	d ₂	h	L
1107763	M3	4,5	0,7-1,4	6
1107771				8
1107798				10
1107801				12
1107828				(15)
1674412				16
1107836				20
1107844				25
1107852	M4	5,5	0,7-1,4	8
1107860				10
1107879				12
1107887				(15)

Article#	d ₁	d ₂	h	L
1674420	M4	5,5	0,7-1,4	16
1107895				20
1107909				25
1107917				30
1107941	M5	6,5	0,8-1,4	8
1107968				10
1107976				12
1107984				(15)
1674439				16
1107992				20
1108018				25
1108026				30
1108050	M6	7,5	0,8-1,4	10
1108069				12
1108077				(15)
1674528				16
1108085				20
1108093				25
1108107				30
1108123				40
1108158				50
1108166	M8	9	~1	10
1108174				(15)
1674846				16
1108182				20
1108190				25
1108204				30
1108603				35
1108611				40